

CORE6410 Process Card

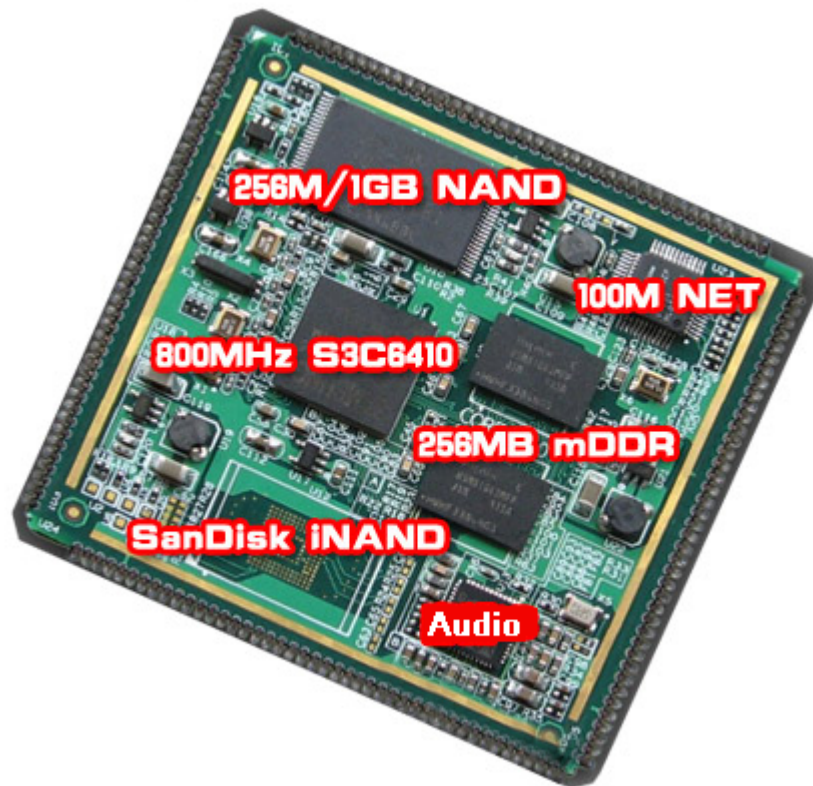

Features

- Dimensions: 60 x 60 x 2.8 mm , 8 layer.
- ARM11 Samsung S3C6410, ARM1176JZF-S, up to 667MHz
- 256MByte MoblieDDR, 266MHz
- 1GByte NAND Flash(support 8GByte NAND Flash)
- iNAND Flash interface (Can support 8GByte iNAND Flash)
- Audio I/O: WM9713 chips, Support two-channel Audio Output/Input, GSM call can be used with GSM module
- 100M Ethernet, DM9000 chips
- 170pin expansion interfaces (QFP package)
- The modular is led out most signals of ARM11 S3C6410, like Matrix Keypad, USB OTG, USB HOST, SDIO, LCD, Touch Screen, Camera, AC97, UART, SPI, I2C, ADC, DAC, PWM, EXT INT, GPIO and so on.
- Support Wince 6.0, Linux2.6 and Android 2.1
- Power supply: 3.7V - 6.5V
- Temperature: 0 to +70 Celsius

General Description

CORE6410 processor card is designed specially to be the heart of your next embedded design. The tiny board integrates Samsung S3C6410 processor (ARM1176JZF-S, up to 800MHz). The processor card takes use of all common features of S3C6410 and the interface between the processor card and your carrierboard is through 170-pin expansion interfaces(QFP package). The Net and audio chip is integrated into the core board. The Audio, Net, USB, LCD, I/O and all other hardware interfaces are all expanded via these interfaces.

Integration of the CoreWind Core6410 processor card to customer special design is fully supported by CoreWind technologies. CoreWind also designed an expansion board which can fully evaluate Core6410. The whole system is called Real6410. CoreWind offers Linux 2.6.28, WinCE6.0, Android2.1 BSP for this board. Customers can leverage our experience to increase your own productivity. The optimal embedded microprocessor solution provides users with a flexible development environment based on S3C6410 and a shortened development timeframe.

Mother board

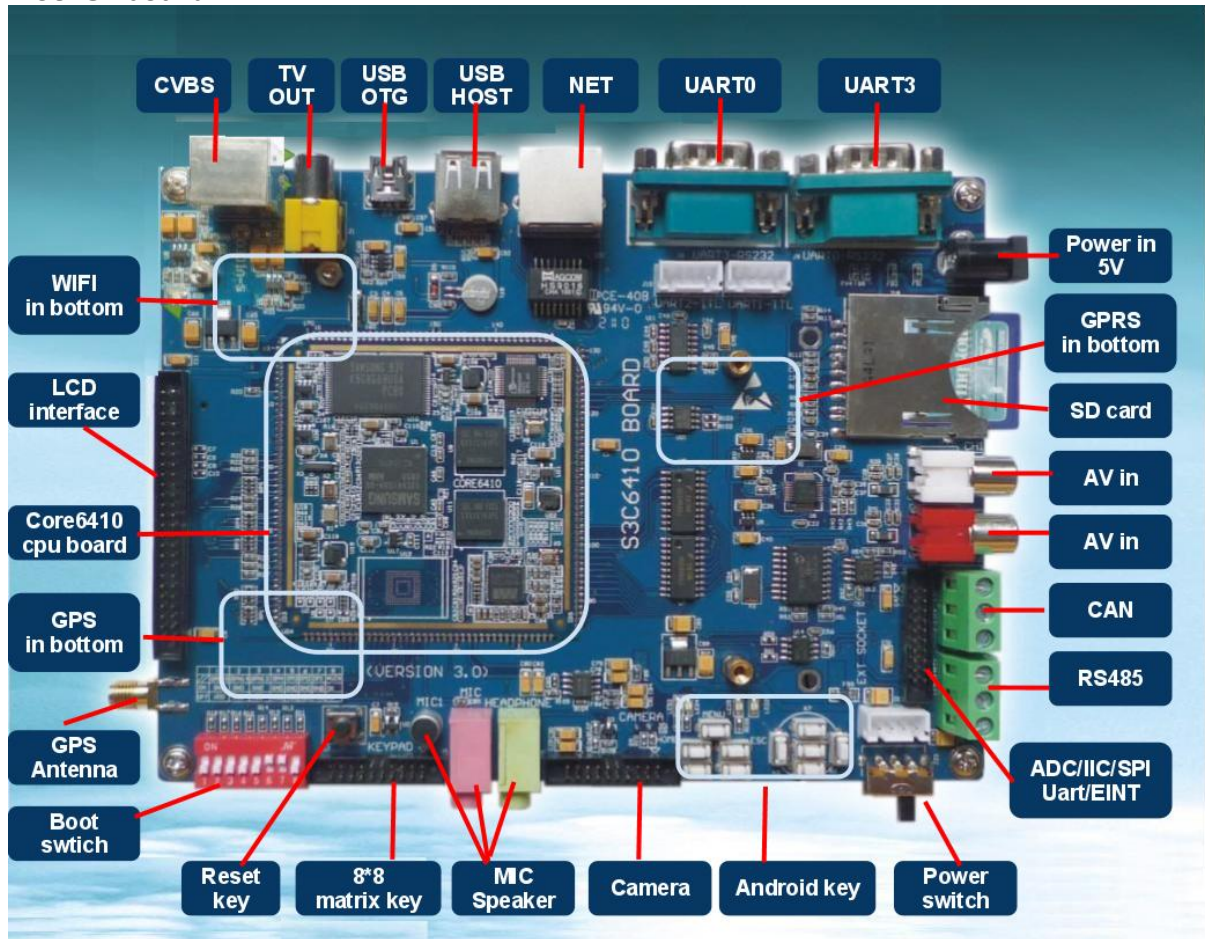

Layout and Functional Block Diagram

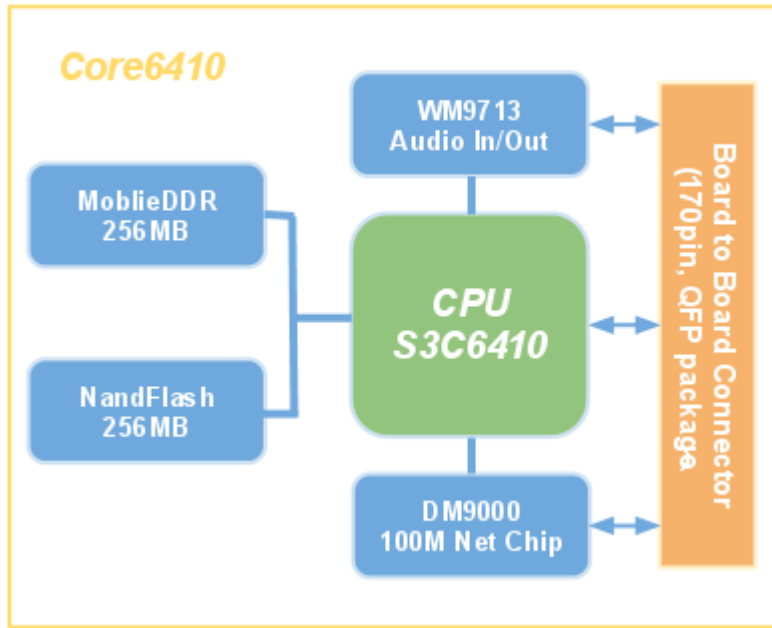

CoreWind Core6410 Functional Block Diagram

Dimensions

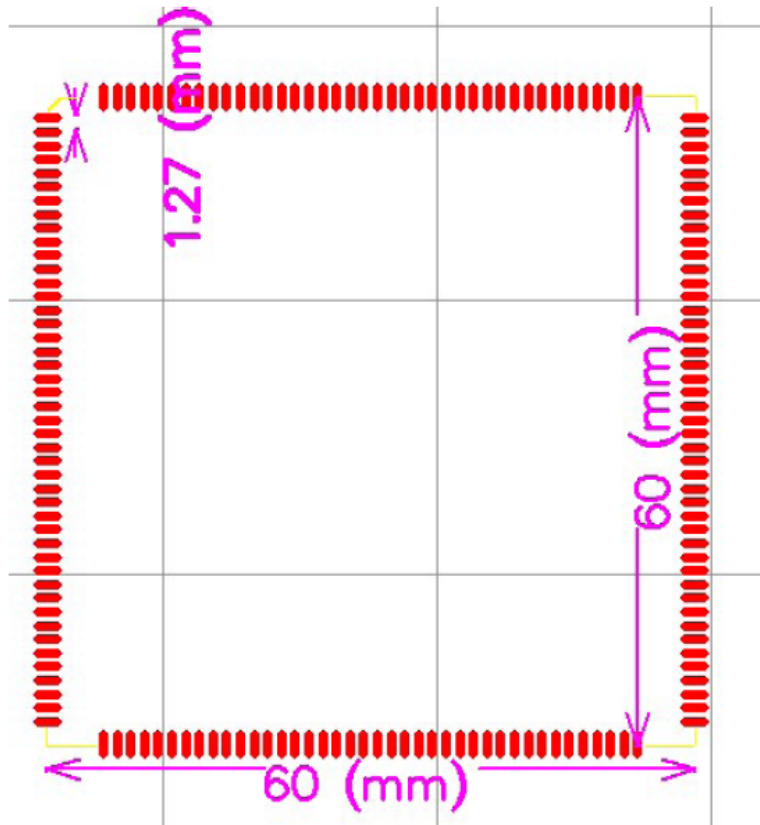

- Length** : 60mm
- Width** : 60mm
- Height** : 2.85mm
- Pin pitch** : 1.27mm

170-Pin Connector

CoreWind Core6410 processor card is connected to carrierboard via 1.27mm space 170-pin QFP package.

Pin	Name	Function explanation	Notes	other
1	KP_COL3	Keypad column 3		IO
2	KP_COL4	Keypad column4		IO
3	KP_COL5	Keypad column5		IO
4	KP_COL6	Keypad column6		IO
5	KP_COL7	Keypad column7		IO
6	EINT20	External Interrupt 20		IO
7	EINT21	External Interrupt 21		IO
8	PWR_ON/OFF	Power enable , high enable		
9	GND	GND		
10	CLK_32K	32.768 clock output		
11	SD0_CD	SDIO 0 Chip select, low enable	Pull-up resistor 10k	IO/ENT12
12	SD0_D0	SDIO 0 data bit 0	Pull-up resistor 10k	IO
13	SD0_D1	SDIO 0 data bit 1	Pull-up resistor 10k	IO
14	SD0_C2	SDIO 0 data bit 2	Pull-up resistor 10k	IO
15	SD0_C3	SDIO 0 data bit 3	Pull-up resistor 10k	IO
16	SD0_CLK	SDIO 0 output clock	Pull-up resistor 10k	IO
17	SD0_CMD	SDIO 0 command signal	Pull-up resistor 10k	IO
18	XVD0	LCD Pixel Data bit 0	B0	IO
19	XVD1	LCD Pixel Data bit 1	B1	IO
20	XVD2	LCD Pixel Data bit 2	B2	IO
21	XVD3	LCD Pixel Data bit 3	B3	IO
22	XVD4	LCD Pixel Data bit 4	B4	IO
23	XVD5	LCD Pixel Data bit 5	B5	IO
24	XVD6	LCD Pixel Data bit 6	B6	IO
25	XVD7	LCD Pixel Data bit 7	B7	IO
26	XVD8	LCD Pixel Data bit 8	G0	IO
27	XVD9	LCD Pixel Data bit 9	G1	IO
28	XVD10	LCD Pixel Data bit 10	G2	IO
29	XVD11	LCD Pixel Data bit 11	G3	IO
30	XVD12	LCD Pixel Data bit 12	G4	IO
31	XVD13	LCD Pixel Data bit 13	G5	IO
32	XVD14	LCD Pixel Data bit 14	G6	IO
33	XVD15	LCD Pixel Data bit 15	G7	IO
34	XVD16	LCD Pixel Data bit 16	R0	IO
35	XVD17	LCD Pixel Data bit 17	R1	IO
36	XVD18	LCD Pixel Data bit 18	R2	IO

37	XVD19	LCD Pixel Data bit 19	R3	IO
38	XVD20	LCD Pixel Data bit 20	R4	IO
39	XVD21	LCD Pixel Data bit 21	R5	IO
40	XVD22	LCD Pixel Data bit 22	R6	IO
41	XVD23	LCD Pixel Data bit 23	R7	IO
42	XHSYNC	LCD Horizontal Synchronization		IO
43	XVSYNC	LCD Vertical Synchronization		IO
44	XVDEN	LCD DEN signal		IO
45	XVCLK	LCD Pixel Clock		IO
46	CTS1	UART1 Clear To Send		IO
47	RXD1	UART1 Receive data		IO
48	RTS1	UART1 Request To Send		IO
49	TXD1	UART1 Transmit data		IO
50	GND	GND		
51	EINT0	External Interrupt 0		IO
52	EINT1	External Interrupt 1		IO
53	EINT2	External Interrupt 2		IO
54	EINT5	External Interrupt 5		IO
55	EINT6	External Interrupt 6	Only high enable	IO
56	EINT7	External Interrupt 7		IO
57	EINT10	External Interrupt 10		IO
58	EINT11	External Interrupt 11		IO
59	EINT13	External Interrupt 13	nand boot choose	IO
60	EINT14	External Interrupt 14	nand boot choose	IO
61	EINT15	External Interrupt 15	nand boot choose	IO
62	EINT16	External Interrupt 16		IO
63	EINT17	External Interrupt 17		IO
64	EINT18	External Interrupt 18		IO
65	MIC1	MIC input		
66	HOST_D-	USB HOST D- pins		
67	HOST_D+	USB HOST D+ pins		
68	PWM1	PWM output 1		IO
69	PWM0	PWM output 0		IO
70	BBP	MIC Differential input +	Link GSM audio out	
71	BBN	MIC Differential input -	Link GSM audio out	
72	SPKL	Audio left output		
73	SPKR	Audio right output		
74	MIC_MTN	Audio output +	Link GSM audio in	
75	MIC_MTP	Audio output -	Link GSM audio in	
76	MICP	MIC input +		

77	MICN	MIC input -		
78	HS_DET	Headset Detection	Headset Detection	
79	LOUT	Headset Left channel		
80	ROUT	Headset right channel		
81	AC97_W	Aduio chips Touch function	Five Touch pins	
82	AC97_Y-	Aduio chips Touch Y-		
83	AC97_Y+	Aduio chips Touch Y+		
84	AC97_X-	Aduio chips Touch X-		
85	AC97_X+	Aduio chips Touch X+		
86	OM1	Boot mode choose		
87	OM2	Boot mode choose		
88	OM3	Boot mode choose		
89	OM4	Boot mode choose		
90	XciYDATA0	Camera data bit 0		IO
91	XciYDATA1	Camera data bit 1		IO
92	XciYDATA2	Camera data bit 2		IO
93	XciYDATA3	Camera data bit 3		IO
94	XciYDATA4	Camera data bit 4		IO
95	XciYDATA5	Camera data bit 5		IO
96	XciYDATA6	Camera data bit 6		IO
97	XciYDATA7	Camera data bit 7		IO
98	XciCLK	Camera clock signal		IO
99	XciHREF	Camera Horizontal Synchronization		IO
100	XciPCLK	Camera Pixel clock signal		IO
101	XciRSTn	Camera reset signal		IO
102	XciVSYNC	Camera Vertical Synchronization		IO
103	RXD0	UART0 Receive data		IO
104	TXD0	UART0 Transmit data		IO
105	CTS0	UART0 Clear To Send		IO
106	RTS0	UART0 Request To Send		IO
107	RXD2	UART2 Receive data		IO
108	TXD2	UART2 Transmit data		IO
109	RXD3	UART3 Receive data		IO
110	TXD3	UART3 Transmit data		IO
111	XirSDBW	IR control signal		IO
112	GND	GND		
113	NET_SPEED	NET speed led output		
114	NET_LINK	NET link led output		
115	AVDD25	2.5V Power output		
116	NET_TX	NET TX		

117	NET_TX+	NET TX+		
118	NET_RX-	NET RX-		
119	NET_RX+	NET RX+		
120	SPIO_MISO	Slave data out, master data in		IO/EINT
121	SPIO_CLK	SPI Clock		IO/EINT
122	SPIO_MOSI	Slave data in, master data out		IO/EINT
123	SPIO_CS	SPI Enable		IO/EINT
124	SPI1_MISO	Slave data out, master data in	SD2_CMD	IO/EINT
125	SPI1_CLK	SPI Clock	SD2_CLK	IO/EINT
126	SPI1_MOSI	Slave data in, master data out		IO/EINT
127	SPI1_CS	SPI Enable		IO/EINT
128	SD1_CD	SD channel 1 enable signal		IO
129	SD1_CLK	SD channel 1 clock signal		IO
130	SD1_CMD	SD channel 1 command signal		IO
131	SD1_D0	SD channel 1 data bit 0		IO
132	SD1_D1	SD channel 1 data bit 1		IO
133	SD1_D2	SD channel 1 data bit 2		IO
134	SD1_D3	SD channel 1 data bit 3		IO
135	SD1_D4	SD channel 1 data bit 4	SD2_D0	IO
136	SD1_D5	SD channel 1 data bit 5	SD2_D1	IO
137	SD1_D6	SD channel 1 data bit 6	SD2_D2	IO
138	SD1_D7	SD channel 1 data bit 7	SD2_D3	IO
139	AIN0	ADC channel 0		
140	AIN1	ADC channel 1		
141	AIN2	ADC channel 2		
142	AIN3	ADC channel 4		
143	TS_YM	Touch Y-		
144	TS_YP	Touch Y+		
145	TS_XM	Touch X-		
146	TS_XP	Touch X+		
147	IIC0_SCL	IIC clock signal		
148	IIC0_SDA	IIC data signal		
149	DAC0	TV out 0		
150	DAC1	TV out 1		
151	GND	GND		
152	OTG_D-	USB OTG D-		
153	OTG_D+	USB OTG D+		
154	OTG_ID	USB OTG ID signal		
155	OTGDRV_VBUS	VBUS power output enable signal		
156	DVBUS	USB OTG power input check signal		

157	nRESET	Reset signal		
158	VDD_RTC	RTC power input	1.8-3.0V	
159	VDDMAX	system power input	3.7-6.5V	
160	KP_ROW0	Keypad row 0		IO
161	KP_ROW1	Keypad row 1		IO
162	KP_ROW2	Keypad row 2		IO
163	KP_ROW3	Keypad row 3		IO
164	KP_ROW4	Keypad row 4		IO
165	KP_ROW5	Keypad row 5		IO
166	KP_ROW6	Keypad row 6		IO
167	KP_ROW7	Keypad row 7		IO
168	KP_COL0	Keypad column 0		IO
169	KP_COL1	Keypad column 1		IO
170	KP_COL2	Keypad column 2		IO

Order Information

Order No.	CR300
Item	CoreWind Core6410 Process card
Price	Please contact CoreWind(www.armdevs.com)

**CoreWind Info&Tech(HK) Limited**

Shangwudasha, NanShan Distric, Shenzhen, China 518020

Tel: 0086-755-29638421

Sales Email: market@armdevs.com

Support Email: support@armdevs.com

<http://www.armdevs.com>